



GRANADA
GLAZING

Slim By Design,
Strong By Nature

Crista Slide
Our Sliding Door Range

Reasons to choose the Crista Slide...

Ultra-slim sightlines of only 20mm create a sleek, contemporary finish while maximising your view.

A **fully integrated handle** system delivers a seamless, streamlined appearance.

Choose our **double or triple track options** for enhanced flexibility and effortless operation.

Delivers exceptional **thermal and acoustic performance** for a comfortable, quiet living space.

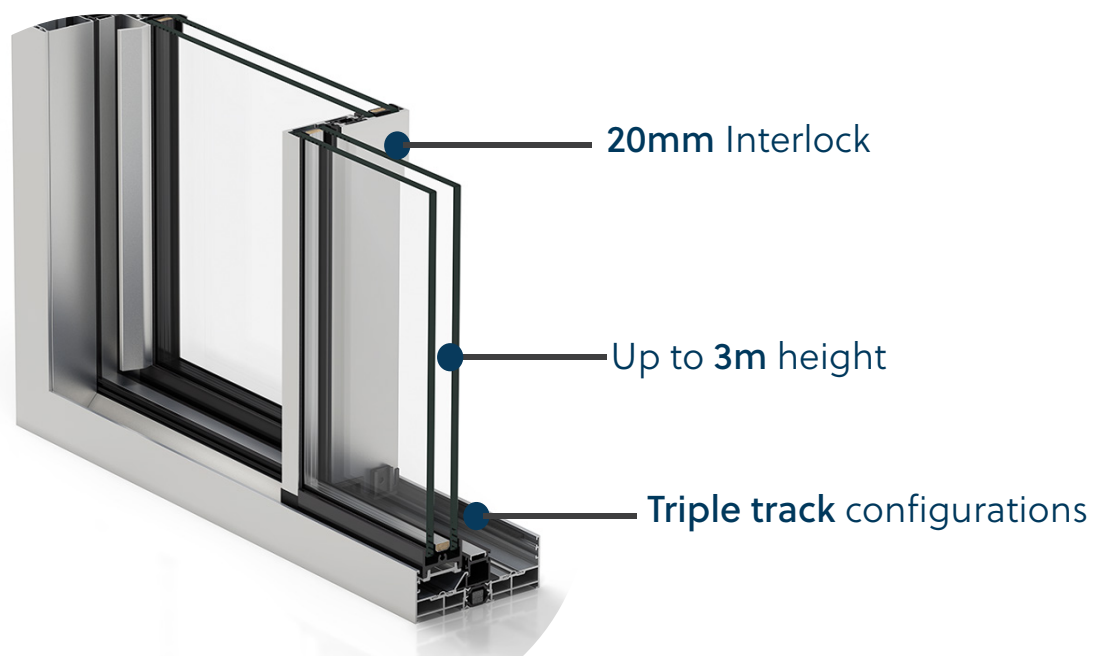

Versatile Configurations

- Left or right opening
- Large sash options
- Multiple colours and hardware options



The important parts...

U Value

Uw 1.3 (W/m²K)

Glazing Options

28mm & 30mm

Maximum Sash Weight

320kg

Maximum Sash Dimensions

Width (L) 2500mm,
Height (H) 3000mm

Sightlines

20mm interlock

Profile Thickness

Door 1.7mm

Water Tightness

Class 7A

Wind Resistance

Class C5

Air Permeability

Class 4

Acoustic Insulation

Rw up to 41 dB

The data in this booklet is based on
1.23 X 1.55 m - 1 sash + 1 fixed light.

Granada Glazing is one of the UK's largest manufacturers of aluminium glazing products. Proudly supplying high-quality systems to trade professionals, architects, and commercial clients for over 45 years. Established in 1980, we've built our reputation on quality, innovation, and customer trust.

Our purpose-built manufacturing facility, located in the heart of Yorkshire, is equipped with the latest technology, enabling us to deliver bespoke, made-to-measure glazing solutions with precision and speed.

From design and production to customer support and aftercare, our team is with you every step of the way.



Granada Glazing Ltd

Campbell Way,
Dinnington,
S25 3QD

info@granadaglazing.com

01909 499899

